

PLEASE NOTE THAT THE MINIBUS MUST NOT BE DRIVEN IF THERE ARE ANY WARNING LIGHTS SHOWING ON THE DASHBOARD



**West Kirby**  
Grammar School

# Minibus Policy

<b>Approved by:</b>	Full Governing Body
<b>Statutory:</b>	No
<b>Last reviewed on:</b>	December 2025
<b>Next review due by:</b>	Autumn 2026

PLEASE NOTE THAT THE MINIBUS MUST NOT BE DRIVEN IF THERE ARE ANY WARNING LIGHTS SHOWING ON THE DASHBOARD

### **Aims**

The policy relates to West Kirby Grammar School (WKGS) owned minibus, which is used to transport students.

### **Legal Requirements**

The Governing Body of WKGS is responsible for ensuring the minibus operating on behalf of the school fully complies in every respect, with all legal transport and health and safety requirements.

This responsibility is delegated to the Head teacher to ensure its appropriate implementation. The law

requires that a minibus must:

- Be adequately insured
- Be well maintained
- Have a valid MOT certificate (if more than one-year-old)
- Have road tax
- Correct seating with correctly fitted seat belts

The school will not pay fines for parking, speeding or other motoring offences. The school will not provide legal support for staff charged with any motoring or traffic offenses. Personal use of the minibuses is not permitted nor are they available for private hire.

### **Responsibilities**

The Director of Finance will either directly or by delegation to the Finance Officer:

- Ensure that the proper insurance, licences and permits are held and kept up to date
- Ensure that minibuses will not be used until defects which have safety implications are rectified
- Check driving licences annually
- Ensure that the minibus is maintained in a roadworthy condition, annually serviced, that a service contract is in place for regular safety checks and an annual MOT carried out.
- Ensure that both organisers and drivers are complying with all requirements set out in this policy
- Monitor completed checklists (Appendix 2) at least half termly to ensure they have been correctly filled in and that all checklists are accounted for and the booking system has been used appropriately
- Arrange MIDAS training for staff wishing to drive the minibus (Minibus Driver Awareness Scheme)
- Maintain records of training and keep copies of licence checks (see below). This should be recorded and the check repeated every 12 months.

PLEASE NOTE THAT THE MINIBUS MUST NOT BE DRIVEN IF THERE ARE ANY WARNING LIGHTS SHOWING ON THE DASHBOARD

### **Authorisation to drive the minibus**

All drivers that wish to drive the minibus lite (weighs less than 3.5 tons so no requirement to hold a D1 licence) must have a B licence (standard licence) and have passed MIDAS training. The driver is not authorised to drive if any of the conditions below occur (all drivers have a duty of care to inform the Director of Finance immediately if any condition below is met during the school year):

1. Accumulating more than 6 live points on their licence
2. Have a collision in the minibus unless it was clearly the fault of a third party
3. Acquire a medical condition that would affect their ability to drive
4. They are under 21 years of age (not covered under our insurance)
5. They reach 70 years of age (when they are no longer covered under our insurance)
6. There is a change in DBS clearance

### **Points 1 to 3**

A MIDAS refresher would need to be taken and passed before the member of staff would be permitted to drive the minibuses again.

We may at our discretion request a local re-familiarisation assessment (or in the case of health concerns, a health check) before the member of staff drives the minibuses again.

A central record is held of copies of licence checks for those members of staff who are authorised to drive the minibus, and this is updated annually by the Director of Finance or nominated person. These checks ensure that all drivers are both licenced and insured to do so, based on the category of driving licence they hold. This provides staff with a "Licence Check Code" or give permission for WKGS to obtain the Licence Check Code.

Below is the link on the Gov.uk website to undertake such checks for free.

<https://www.gov.uk/view-driving-licence>

This checking service enables drivers to view or share their driving licence information including:

- view your driving record, for example vehicles you can drive
- check your penalty points or disqualifications
- create a licence 'check code' to share your driving record with someone, for example a car hire company The 'check code' will be valid for 21 days.

Driver information required:

- driving licence number
- National Insurance number
- the postcode on the driving licence

Once the check is carried out, the driver must complete the MiDAS driver licence confirmation form (available from the finance office) and return it to the Director of Finance prior to any assessment or training taking place.

PLEASE NOTE THAT THE MINIBUS MUST NOT BE DRIVEN IF THERE ARE ANY WARNING LIGHTS SHOWING ON THE DASHBOARD

### **Minibus management system:**

All staff must use the proper booking procedures for use of the school minibus. Please check availability with the Head of PE and the online booking system. At the time of use keys must be collected from the Finance Office between the hours of 9am and 4pm. Drivers must allow time to complete the pre-journey checklist (Appendix 2).

It is the driver's responsibility to top up the fuel at the end of their journey using the WKGS fuel card, this can be collected at the Finance Office and must be returned at the end of the journey.

### **Driving the minibus**

On a long-distance journey when a member of staff is driving a minibus, it is not acceptable to expect them to exercise general supervisory responsibilities during the journey. The governors, therefore, require that there is an adequate number of adults to both drive and supervise the pupils.

When a driver undertakes a single planned journey of up to two hours, a rest break is voluntary. There must be a second driver for any planned single journey of more than three hours. Neither driver may drive for more than three hours in any four.

- Drivers Should Ensure that pre-use checks of the vehicle are conducted see Appendix 2
- Understand the personal legal implications if procedures are not adhered to. For example, 'It is the driver's licence that will suffer if the vehicle is found to be defective. It is also the driver's responsibility to ensure the safety (including the use of seat belts) and welfare of all passengers. (ROSPA, August 2015)
- Never use a mobile phone as the driver of the vehicle unless it is parked in a safe place with the engine switched off. Making genuine emergency 999 or 112 calls whilst driving is legal.

### **Reversing of Vehicles**

- Reversing vehicles can be particularly hazardous. The best way of avoiding a reversing accident is to avoid reversing a vehicle wherever possible.
- Always check behind the vehicle before reversing - if necessary, ask someone to watch the area into which you will be reversing.
- If you use a guide, ensure they can be seen at all times whilst manoeuvring - if two members of staff are present, one must at all times be the guide when reversing.
- Ensure rear view mirrors are clean and properly adjusted at all times.

### **Dealing with 'road rage'**

- If threatened by another driver, do not retaliate by flashing lights, sounding the horn or making offensive gestures; this only attracts a response and will often make a situation worse
- If forced to stop, stay in the vehicle with windows closed and doors locked and be prepared to drive off
- If necessary, use your mobile phone to contact the police for assistance

**PLEASE NOTE THAT THE MINIBUS MUST NOT BE DRIVEN IF THERE ARE ANY WARNING LIGHTS SHOWING ON THE DASHBOARD**

- Note the registration number of the vehicle, and the make and colour, plus a description of the driver and occupants so you can give the police these details

At the academy's discretion, with advanced notification to the Director of Finance and with the Headteacher's approval, a teacher or other member of staff without MIDAS training may drive if the following criteria is met:

- The minibus has a Section 19 permit (for home to school routes) They have held their driving licence for two years or longer
- They are aged between 21 and 70
- The Maximum Authorised Mass (MAM) is weighing less than 3.5 tons

All drivers must follow the Minibus Protocol – see **appendix 1**.

### **Accidents/Incidents**

**Minor** - The minibus is still drivable and legal

If an accident occurs, the minibus driver or additional member of staff should ensure that the students are safe and uninjured.

The driver should ensure that the details of other vehicles at the scene are taken and recorded, e.g. type of vehicle, number plate, insurance details and name and address of other driver(s). Where possible photographs should be taken of the accident/incident to assist with any insurance claim.

An incident form must be completed on return to the academy and given to the Director of Finance or nominated person.

**Major** - The minibus is not drivable, or injuries sustained to staff or students

The driver must telephone the emergency services.

Then telephone the senior member of staff on call to advise them of the incident. The senior staff member will assess the situation and advise accordingly.

The staff and students must go to an area of safety away from traffic and staff must always stay with the students.

The driver or additional staff member should always keep the senior staff member up to date on events. Then telephone the senior member of staff on call to advise them of the incident. The senior staff member will assess the situation and advise accordingly.

PLEASE NOTE THAT THE MINIBUS MUST NOT BE DRIVEN IF THERE ARE ANY WARNING LIGHTS SHOWING ON THE DASHBOARD

### **Breakdown**

The designated senior member of staff will have contact details of the recovery service and these are also held in the minibus.

If the minibus breaks down the driver must call the recovery services who will attempt to repair the vehicle and if unable to, will arrange for the bus to be towed back to the academy.

The staff and students must always go to an area of safety away from traffic and stay with the students.

If the minibus cannot be repaired on the roadside, then the driver must call the senior member of SLT on call who will arrange transport to return the staff and students to the Academy.

### **Maintenance**

The minibuses will be serviced annually and have a valid MOT certificate and insurance in place by the Director of Finance

The minibus will be checked every 10 weeks by an independent party to ensure that each minibus meets the requirements set by the DVLA.

Maintenance of the minibuses will be routinely checked by the minibus technician Tom Davies (a member of our site team), which should include tyre pressure, washer bottles, coolant etc.

Before the minibus is driven a Pre Drive Safety Check will be done by the driver and any defects will be reported to the minibus technician to arrange repair.

### **APPENDICES**

APPENDIX 1 - Minibus Protocol APPENDIX 2 – Minibus checklist

APPENDIX 2 – Minibus checklist

APPENDIX 3 - First Aid Kit and Other Equipment for Minibus

PLEASE NOTE THAT THE MINIBUS MUST NOT BE DRIVEN IF THERE ARE ANY WARNING LIGHTS SHOWING ON THE DASHBOARD

## **APPENDIX 1 – Minibus Protocol**

- 1) Only an authorised driver can drive the minibus – See minibus policy
- 2) The vehicle must be booked via the School's booking system
- 3) The driver must check vehicle before departure and complete a Pre-Drive Safety Check form - See Appendix 2
- 4) Drivers are required to have a zero intake of alcohol. Some medication may impair a driver's ability, staff who are taking medicines of this nature are not to drive the minibus
- 5) The driver is fully responsible for vehicle.
- 6) Ensure attendance officer, or if out of hours, the SLT member on call are given a register of students and staff on board and an itinerary for the journey.
- 7) Where possible, diesel should be purchased from a designated garage on account – West Kirby Grammar School using the fuel card.
- 8) The driver must ensure that all the doors are unlocked before journey starts.
- 9) The driver must have school emergency contact number and the breakdown service number and membership number.
- 10) On your return, the driver must ensure all doors locked, windows closed and lights off.
- 11) The driver to ensure that all rubbish is removed from vehicle. A dustpan and brush are provided to sweep the minibus after use.
- 12) The driver must report any faults to minibus technician, this can be done by email. Please copy in the Site Manager and the Finance Officer
- 13) After the journey please can the driver return the keys to the PE Office or the Finance Office.

### **PLEASE NOTE:**

The dimension of the vehicle is shown inside the Minibus Log along with the Insurance & Breakdown details.

PLEASE NOTE THAT THE MINIBUS MUST NOT BE DRIVEN IF THERE ARE ANY WARNING LIGHTS SHOWING ON THE DASHBOARD

## APPENDIX 2: Minibus Checklist

Please allow sufficient time to complete this checklist and hand in to Finance Office.

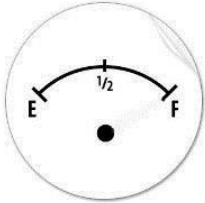
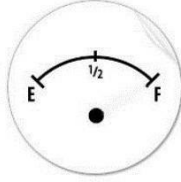
<p>Legally, the responsibility for ensuring the mechanical serviceability of a minibus lies with the driver of the moment. Please ensure you have checked everything.</p>	
Name of driver/s	
Mileage at start of journey	
Mileage at end of journey	
<p>Fuel gauge reading on pick up</p> 	<p>Fuel gauge reading on return</p> 
<p>I confirm that I have read and signed the Minibus Risk Assessment <input type="checkbox"/> (Please tick)</p>	
Signed:	Date:

Before – exterior condition

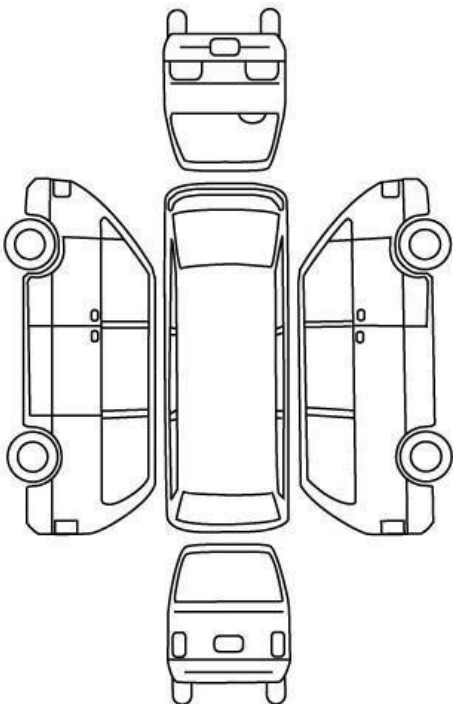

After – exterior condition

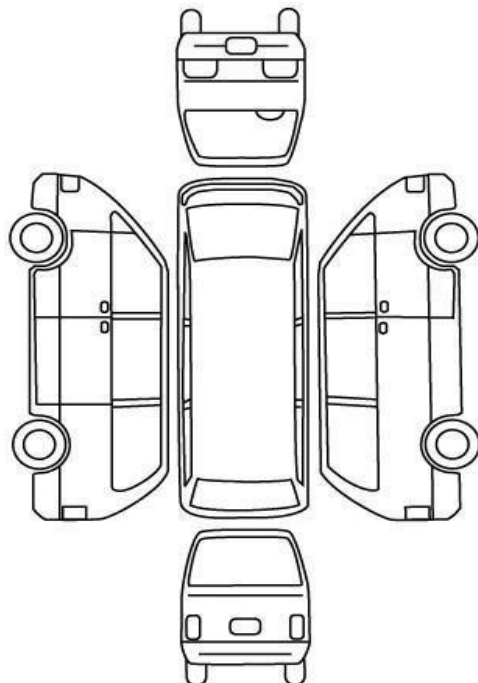

PLEASE NOTE THAT THE MINIBUS MUST NOT BE DRIVEN IF THERE ARE ANY WARNING LIGHTS SHOWING ON THE DASHBOARD

<b>Exterior Check</b>	OK	NOT OK
Oil Level ( <i>once only at start of the day</i> )		
Coolant level ( <i>once only at start of the day</i> )		
Windscreen washer fluid level ( <i>once only at start of the day</i> )		
Brake fluid level ( <i>once only at start of the day</i> )		
Windscreen and windows are clean and undamaged		
Wiper blades are clean and undamaged		
Exterior mirrors are correctly adjusted, clean, and unobstructed		
Lights, including brake lights and indicators, are clean and working		
Tyre pressures (visual check of all tyres)		
Tyre tread (visual check of all tyres)		
Any cuts and bulges in the tyres?		
Area around each wheel is clear of debris (wheel arch)		
Doors open and close properly		
Damage to bodywork or sharp edges		
Fluid leaks		

PLEASE NOTE THAT THE MINIBUS MUST NOT BE DRIVEN IF THERE ARE ANY WARNING LIGHTS SHOWING ON THE DASHBOARD

<b>Interior Check</b>	OK	NOT OK
Mirrors are correctly adjusted, clean, and unobstructed		
Position of driving seat so that all the controls can be operated comfortably		
Pressure on brake pedal		
Wipers and washers are working properly		
Location of first aid kit and fire extinguisher (See APPENDIX 3)		
Relevant paperwork (insurance, MOT, emergency numbers)		
Emergency equipment – high visibility jackets, warning triangle		
Horn is in working order		
Interior lights are working		
No warning lights lit on the dashboard		
All seats are fixed and secure and all seat belts are undamaged and working properly		
Heating and ventilation systems working		
Luggage is securely stowed, and aisles and exits are clear		
Amount of petrol purchased on fuel card	£	

PLEASE NOTE THAT THE MINIBUS MUST NOT BE DRIVEN IF THERE ARE ANY WARNING LIGHTS SHOWING ON THE DASHBOARD

### **APPENDIX 3: First Aid Kit and Other Equipment for Minibus**

#### **First Aid Kit:**

- 10 antiseptic wipes, foil packed
- conforming disposable bandage (not less than 7.5 cm wide)
- triangular bandages
- packet of 24 assorted adhesive dressings
- large sterile un-medicated ambulance dressings (not less than 15 x 20 cm)
- 2 sterile eye pads with attachments
- 12 assorted safety pins
- pair of rustproof blunt-ended scissors
- Disposable gloves
- Mouth mask for resuscitation.

Make sure that even minor uses of a first aid kit are recorded and reported to reception and an accident form completed and that stock is replaced after use. Check that all items are 'in date' and replace any that have passed their expiry date.

#### **Fire Extinguisher:**

- At least one fire extinguisher for accessible minibuses) which complies with BS 5432 (or an equivalent, e.g. BSEN 3) and
- has a minimum test rating of 8A or 21B, and
- contains foam (please note they must not contain Halon)

#### **Other Equipment:**

It is mandatory that the following should also be carried:

- Pen and paper
- The organisation's internal instructions and contact details
- Insurance details
- Motoring breakdown policy details
- An emergency warning triangle or a flashing beacon (not fitted to the vehicle)
- A working torch
- Sterile gloves and mouth masks.
- Sick Bags
- Grab bag containing emergency contact list
- Set of 16 hi-visibility vests
- Set of 16 disposable foil blankets
- Torch